

Functional Safety – Incremental encoders

Sine wave output, optical – SIL3 / PLe

Sendix 5814 FS3 / 5834 FS3 (Shaft / Hollow shaft)

SinCos

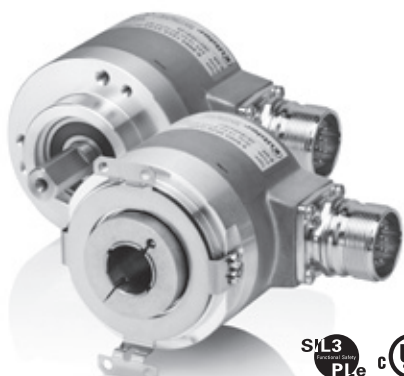

The incremental encoders 5814 FS3 and 5834 FS3 of the Sendix SIL family are suited for use in safety-related applications up to SIL3 according to EN 61800-5-2 or PLe to EN ISO 13849-1.

These encoders are particularly suited for applications in the field of safe drive technology.

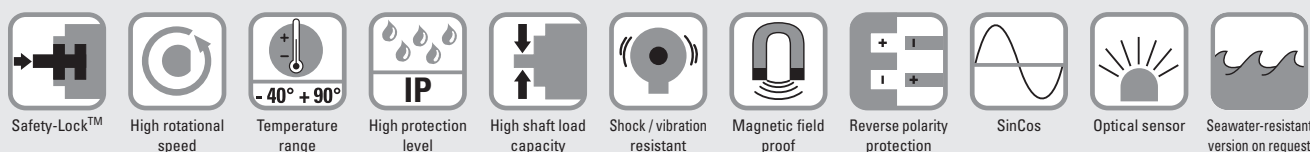

Functional Safety

- Certified by the German Institute for Occupational Safety (IFA)
- Suitable for applications up to SIL3 acc. to EN 61800-5-2
- Suitable for applications up to PLe acc. to EN ISO 13849-1
- With incremental SinCos tracks
- Certified mechanical mounting + electronic

Flexible

- Shaft and hollow shaft versions
- Cable and connector variants
- Various mounting options available

Order code
Shaft version

8.5814FS3 . 1 XXXX . XXXX
Type a b c d e

If for each parameter of an encoder the underlined preferred option is selected, then the delivery time will be 10 working days for a maximum of 10 pieces. Qts. up to 50 pcs. of these types generally have a delivery time of 15 working days.



a Flange

1 = clamping flange, ø 58 mm, IP65

b Shaft (ø x L)

2 = 10 x 20 mm, with flat

A = 10 x 20 mm, with feather key

c Output circuit / Power supply

1 = SinCos / 5 V DC

2 = SinCos / 10 ... 30 V DC

d Type of connection

1 = axial cable (1 m PVC)

2 = radial cable (1 m PVC)

3 = M23 connector, 12 pin, axial

4 = M23 connector, 12 pin, radial

5 = M12 connector, 8 pin, axial

6 = M12 connector, 8 pin, radial

e Pulse rate

1024, 2048

optional on request

- seawater-resistant

- special cable length

- Ex 2/22

Order code
Hollow shaft

8.5834FS3 . XXXX . XXXX
Type a b c d e

If for each parameter of an encoder the underlined preferred option is selected, then the delivery time will be 10 working days for a maximum of 10 pieces. Qts. up to 50 pcs. of these types generally have a delivery time of 15 working days.



a Flange

A = with torque stop set, IP65

B = with stator coupling, IP65

b Hollow shaft

3 = ø 10 mm

4 = ø 12 mm

5 = ø 14 mm

K = ø 10 mm, tapered shaft

c Output circuit / Power supply

1 = SinCos / 5 V DC

2 = SinCos / 10 ... 30 V DC

d Type of connection

2 = radial cable (1 m PVC)

4 = M23 connector, 12 pin, radial

4 = M23 connector, 12 pin, radial

E = tangential cable (1 m PVC)

e Pulse rate

1024, 2048

optional on request

- seawater-resistant

- special cable length

- Ex 2/22

Connection technology

Order-No.

Connector, self-assembly (straight)

M12 female connector with coupling nut

05.CMB-8181-0

M23 female connector with coupling nut

8.0000.5012.0000

Cordset, pre-assembled

M12 female connector with coupling nut, PVC cable

05.00.6041.8211.XXXX

M23 female connector with coupling nut, PVC cable

8.0000.6901.XXXX

Further accessories can be found in the accessories section or in the accessories area of our website at: www.kuebler.com/accessories.

Additional connectors can be found in the connection technology section or in the connection technology area of our website at: www.kuebler.com/connection_technology.

You will find an overview of our systems and components for Functional Safety under www.kuebler.com/safety

Functional Safety – Incremental encoders

Sine wave output, optical – SIL3 / PLe Sendix 5814 FS3/5834 FS3 (Shaft / Hollow shaft) SinCos

Notes regarding “Functional Safety”
 These encoders are suitable for use in safety-related systems up to SIL3 acc. to EN 61800-5-2 and PLe to EN ISO 13849-1 in conjunction with controllers or evaluation units, which possess the necessary functionality.
 Additional functions can be found in the operating manual.

Safety characteristics	
Relevant standards	EN ISO 13849-1 / EN 61800-5-2, EN 61508
Classification	PLe / SIL3
System structure	2 channel (Cat. 4 / HFT = 1)
PFH_d value ¹⁾	1.09 x 10 ⁻⁸ h ⁻¹
Proof-test interval	20 years

Electrical characteristics	
Supply voltage	5 V DC ± 5% or 10 ... 30 V DC
Current consumption (without output load)	5 V DC max. 70 mA 10 ... 30 V DC max. 45 mA
Reverse polarity protection of the power supply (U_B)	yes
UL approval	File 224618
Conforms to CE requirements acc. to	EN 61000-6-2, EN 61000-6-4, EN 61000-6-3
RoHS compliant acc. to	EU guideline 2002/95/EC

SinCos interface	
Max. frequency -3dB	400 kHz
Signal level	1 V _{pp} (± 10%)
Short circuit proof	yes ³⁾
Pulse rate	1024 / 2048 ppr

Mechanical characteristics	
Max. speed, shaft version	without shaft seal (IP65) up to 70°C 12 000 min ⁻¹ , 10 000 min ⁻¹ (continuous) without shaft seal (IP65) up to T _{max} 8 000 min ⁻¹ , 5 000 min ⁻¹ (continuous) with shaft seal (IP67) up to 70°C 11 000 min ⁻¹ , 9 000 min ⁻¹ (continuous) with shaft seal (IP67) up to T _{max} 8 000 min ⁻¹ , 5 000 min ⁻¹ (continuous)
Max. speed, hollow shaft version	without shaft seal (IP65) up to 70°C 9 000 min ⁻¹ , 6 000 min ⁻¹ (continuous) without shaft seal (IP65) up to T _{max} 6 000 min ⁻¹ , 3 000 min ⁻¹ (continuous) with shaft seal (IP67) up to 70°C 8 000 min ⁻¹ , 4 000 min ⁻¹ (continuous) with shaft seal (IP67) up to T _{max} 4 000 min ⁻¹ , 2 000 min ⁻¹ (continuous)
Starting torque, shaft version	without shaft seal (IP65) < 0.01 Nm with shaft seal (IP67) < 0.05 Nm
Starting torque, hollow shaft version	without shaft seal (IP65) < 0.03 Nm
Moment of inertia	Shaft version 4.0 x 10 ⁻⁶ kgm ² Hollow shaft version 7.0 x 10 ⁻⁶ kgm ²
Load capacity of shaft	radial / axial 80 N / 40 N
Weight	approx. 0.45 kg
Protection EN 60529	housing side IP67 shaft side IP65, opt. IP67
Hazardous area approval	optional zone 2 and 22
Working temperature range	-40°C ... +90°C ²⁾
Materials	shaft / hollow shaft stainless steel flange aluminium housing zinc die-cast housing cable PVC
Shock resistance acc. EN 60068-2-27	500 m/s ² , 11 ms
Vibration resistance acc. EN 60068-2-6	200 m/s ² , 10 ... 150 Hz

Functional Safety

Terminal assignment

Output circuit	Type of connection	Cable
1, 2	1, 2, E	Signal: 0 V +V A \bar{A} B \bar{B} \perp
		Cable colour: WH BN GN YE GY PK shield
Output circuit	Type of connection	M23 connector
1, 2	3, 4	Signal: 0 V +V A \bar{A} B \bar{B} \perp
		Pin: 10 12 5 6 8 1 PH ⁴⁾
Output circuit	Type of connection	M12 connector
1, 2	5, 6	Signal: 0 V +V A \bar{A} B \bar{B} \perp
		Pin: 1 2 3 4 5 6 PH ⁴⁾

- +V: Encoder power supply +V DC
- 0 V: Encoder power supply ground (0 V)
- PH \perp : Plug connector housing (shield)
- A, \bar{A} : Cosine signal
- B, \bar{B} : Sine signal

Top view of mating side, male contact base

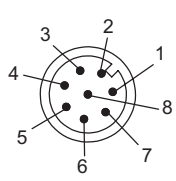

M12 connector, 8-pin

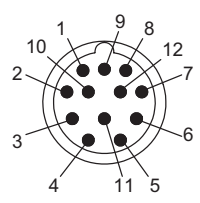

M23 connector, 12-pin

1) The specified value is based on a diagnostic coverage of 99%, that must be achieved with an encoder evaluation unit.
 The encoder evaluation unit must meet at least the requirements for SIL3.
 2) Cable version: -30°C ... +90°C fixed installation

3) Short circuit to 0V or to output, one channel at a time, supply voltage correctly applied
 4) PH = shield is attached to connector housing

Functional Safety – Incremental encoders

Sine wave output, optical – SIL3 / PLc

Sendix 5814 FS3 / 5834 FS3 (Shaft / Hollow shaft)

SinCos

Dimensions shaft version

Clamping flange

Flange type 1 with shaft type 2

(Drawing with cable)

1 3 x M3, 6 [0.24] deep

2 3 x M4, 8 [0.32] deep

$D = 10^{h7}$ [0.39]

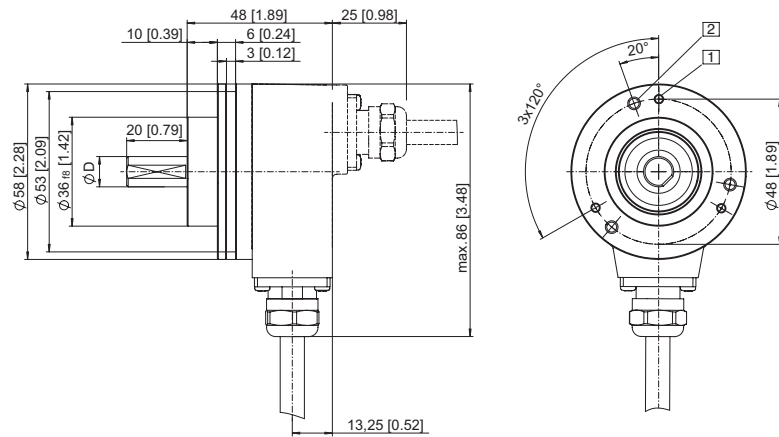

Flange type 1 with shaft type A

(Drawing with M23 connector)

1 3 x M3, 6 [0.24] deep

2 3 x M4, 8 [0.32] deep

3 Feather key DIN 6885 - A - 3x3x6

$D = 10^{h7}$ [0.39]

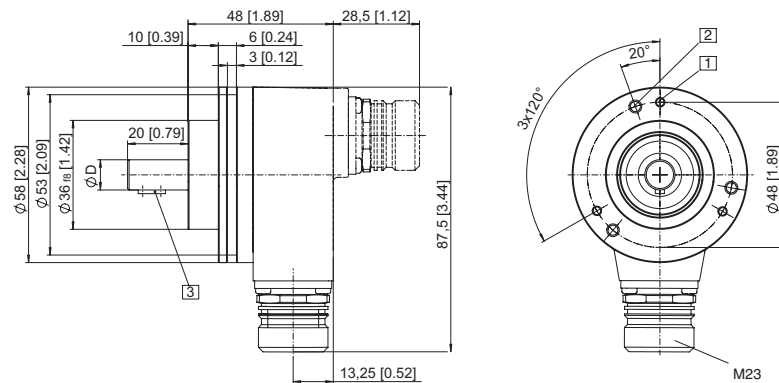

(Drawing with M12 connector)

1 3 x M3, 6 [0.24] deep

2 3 x M4, 8 [0.32] deep

3 Feather key DIN 6885 - A - 3x3x6

$D = 10^{h7}$ [0.39]

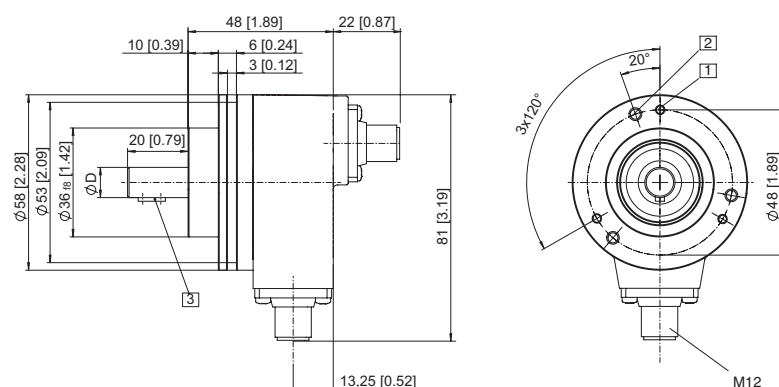

Functional Safety – Incremental encoders

Sine wave output, optical – SIL3 / PLc **Sendix 5814 FS3/5834 FS3 (Shaft / Hollow shaft)** **SinCos**

Dimensions hollow shaft version

**With torque stop set
flange type A**

(Drawing with cable)

1 SW 3

D = \varnothing 10^{H7} [0.39]
 \varnothing 12^{H7} [0.47]
 \varnothing 14^{H7} [0.55]

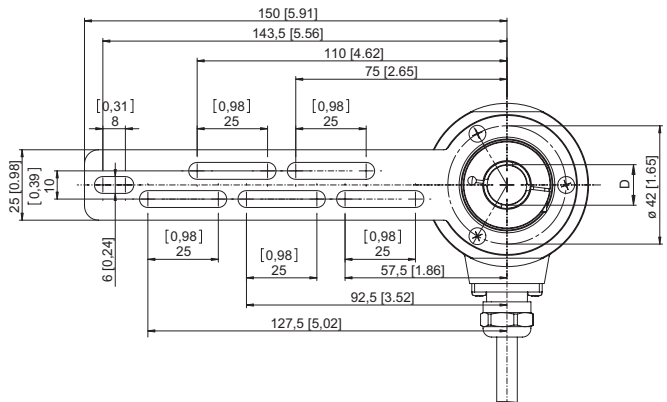
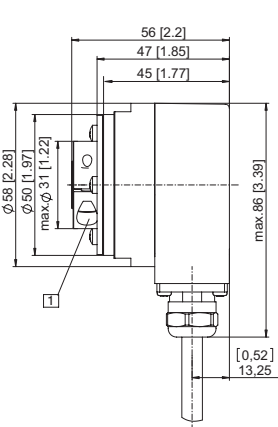

(Drawing with M12 connector)

1 SW 3

D = \varnothing 10^{H7} [0.39]
 \varnothing 12^{H7} [0.47]
 \varnothing 14^{H7} [0.55]

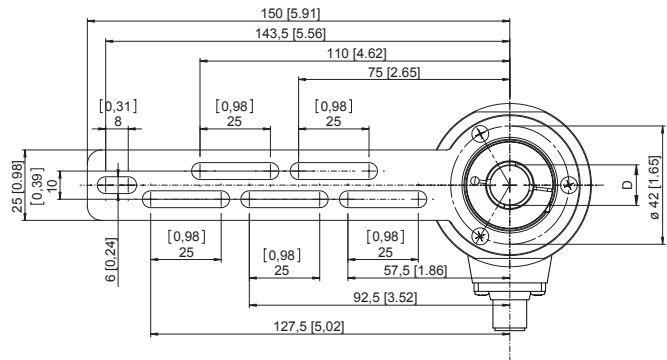
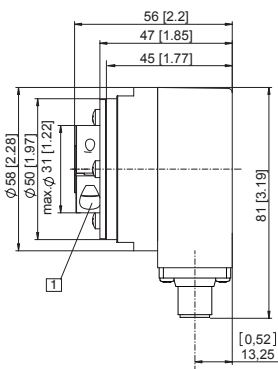

Torque pin with rectangular sleeve
with M4 thread, 10 [0.39] deep

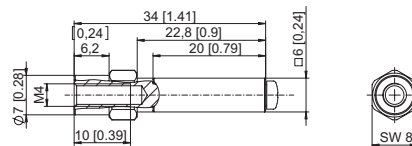

**Flange with stator coupling and hollow shaft
Flange type B**

(Drawing with M23 connector)

1 SW 3

2 for (4x) M3 screw

D = \varnothing 10^{H7} [0.39]
 \varnothing 12^{H7} [0.47]
 \varnothing 14^{H7} [0.55]

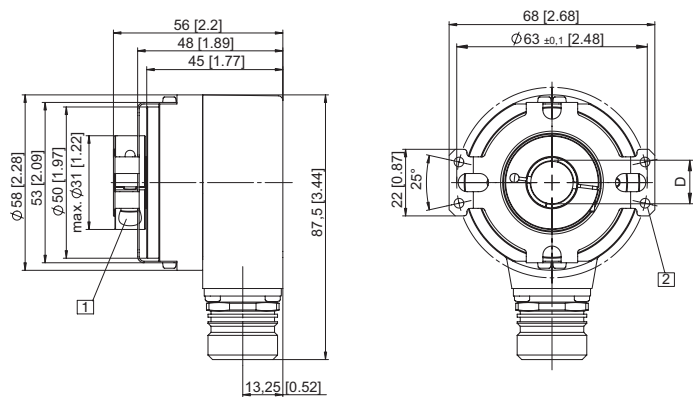

**Flange with stator coupling and tapered shaft
Flange type B**

(Drawing with tangential cable outlet)

1 for (4x) M3 screw

2 Status LED

3 SET button

4 SW 4

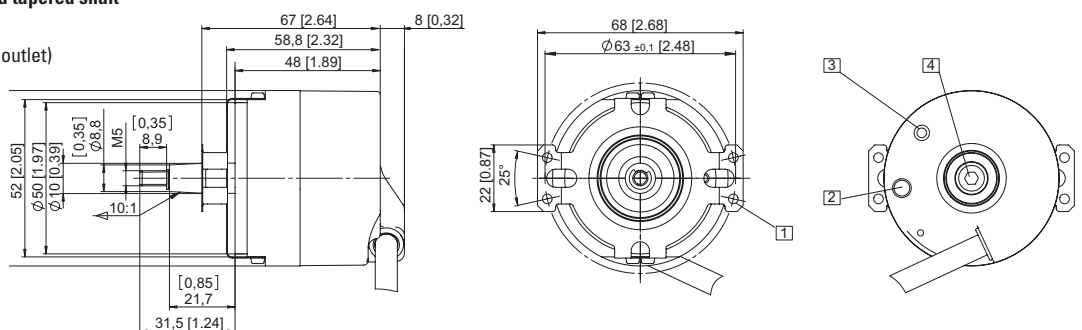

Dimensions in mm [inch]